

**Residual unbalance
< 0,001 gmm***

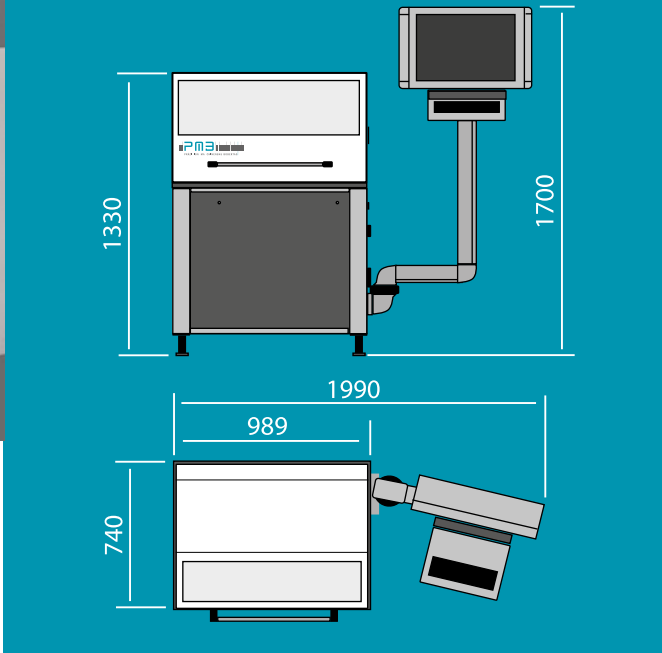

Technical data



CAROBA® Balancer Universal 500

Our CAROBA® Balancer Universal series has a modular design. It is made up of our standardised components, which are configured and assembled according to the balancing task. In combination with our balancing software CAROBA® Soft and the UMS measuring systems, you achieve high, reproducible balancing qualities. From individual parts and prototypes to small and large series. From manual operation to various levels of automation, many expansion stages are available.

Shaft diameter on standard bearing blocks	min / max	mm	1 - 80
Bearing surfaces distance on standard bearing blocks	min / max	mm	30 - 500
Object diameter	max	mm	300
Object weight	min	Gramm	10
	max	Kg	10
On reinforced version	max	Kg	35

Smallest possible residual unbalance*			
On rollers / prisms of standard bearing blocks		gmm	< 0,03
On PMB air bearings		gmm	< 0,001

*Dependent on balancing object, mounting and measuring system

Weight Universal 500	Kg	ca. 350
Power supply	V/Ph	230 V/AC
Fuse protection	Ampere	8AT

Type of drive

Belt drive	Wrap with round belt cord	
Drive power	Watt	117

Balancing speed by

Belt drive	UPM	180 - 9000
Air drive / Depending on object and bearings, more than	UPM	12.000
Self-driven / When using the „Compact“ measuring system, maximal	UPM	96.000
When using the „Pro or Pro-i“ measuring system, maximal	UPM	800.000

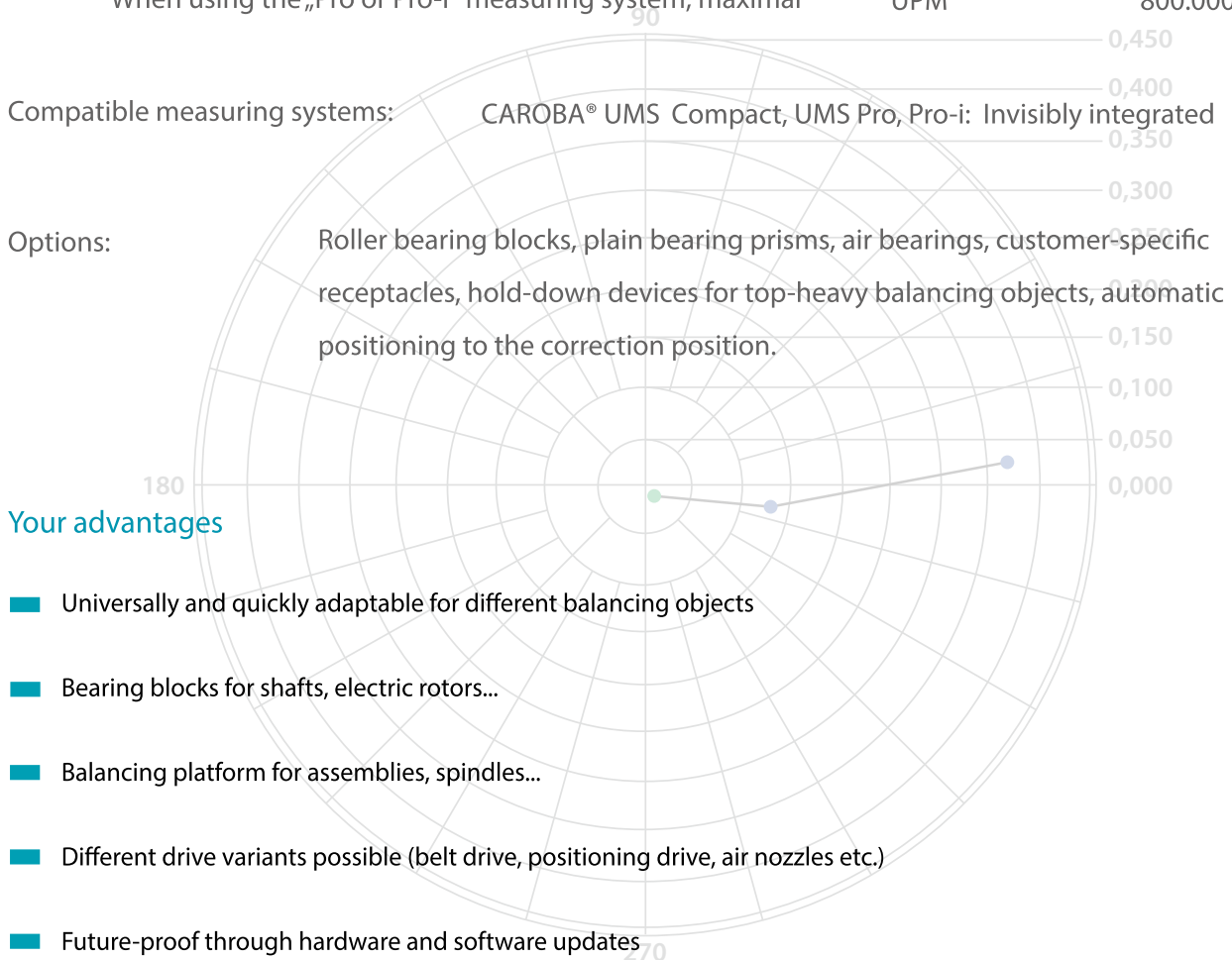

PMB - Präzisionsmaschinenbau Bobertag GmbH, Hertelsbrunnenring 30
 67657 Kaiserslautern / Germany, Phone +49 (0) 631 204 015 0, E-Mail: info@pmb-bobertag.de



06.2019/ EN